

VALVE DIMENSIONS													ADAPT CODE		
(METRIC; MM)							(IMPERIAL; INCHES)								
SIZE	A	B	C	D	S (NS)	S (SD)	ADAPT CODE	SIZE	A	B	C	D	S (NS)	S (SD)	ADAPT CODE
50	221.5	162	125.5	38	43	43	F-05	2	8.72	6.38	4.94	1.50	1.69	1.69	BBG
65	243	182	137	38	48	46	F-07	2 1/2	9.57	7.17	5.39	1.50	1.89	1.81	BAC
80	263.5	200	145.5	38	48	46	F-07	3	10.37	7.87	5.73	1.50	1.89	1.81	BAC
100	303.5	234	170.5	38	54	52	F-07	4	11.95	9.21	6.71	1.50	2.13	2.05	BAC
125	346	276	185	38	57	56	F-07	5	13.62	10.87	7.28	1.50	2.24	2.20	BAD
150	381.5	310	203.5	38	57	56	F-07	6	15.02	12.20	8.01	1.50	2.24	2.20	BAD
200	443	362	239	38	63.5	60	F-12	8	17.44	14.25	9.41	1.50	2.50	2.36	CAE
250	515	426	275	58	68	56	F-12	10	20.28	16.77	10.83	2.28	2.81	2.68	CAE
300	576	490	307	58	78	60	F-12	12	22.68	19.29	12.07	2.28	3.19	3.11	CAE

GEAR OPERATOR DIMENSIONS WITH HANDWHEEL					
(METRIC; MM)					
SIZE	E	F	H	J	ADAPT. CODE
423 (24:1)	104	181	152	121	BAC BAD
420 (30:1)	186	327	305	218	CAE CAF
426 (50:1)	191	327	305	230	CAF
430 (80:1)	208	275	305	272	DBC DAJ DAG DAK GAL DAH
(IMPERIAL; INCHES)					
SIZE	E	F	H	J	ADAPT. CODE
423 (24:1)	4.1	7.13	6	4.77	BAC BAD
420 (30:1)	7.34	12.88	12	8.6	CAE CAF
426 (50:1)	7.52	12.88	12	9.07	CAF
430 (80:1)	8.2	10.81	12	10.72	DBC DAJ DAG DAK GAL DAH

- NOTES:**
 1. REFER TO INDIVIDUAL SMD DRAWINGS FOR FURTHER DETAILS OF VALVE, OPERATOR AND ADAPTABILITY CODES.
 * 2. MINIMUM CLEARANCE REQUIRED FOR COVER OR COMPONENT REMOVAL.

GRINNELL FLOW CONTROL						HIGH PERFORMANCE ANSI CLASS 150 BUTTERFLY VALVE W/ GEAR OPERATOR AND OPTIONAL SWITCHBOX (WAFFER)	
SM1025						SHEET 1 OF 2	
2	5899	ERW	2/23/00	KLS	2/00		
NO	ECN	DRAWN	DATE	CHECK	DATE		

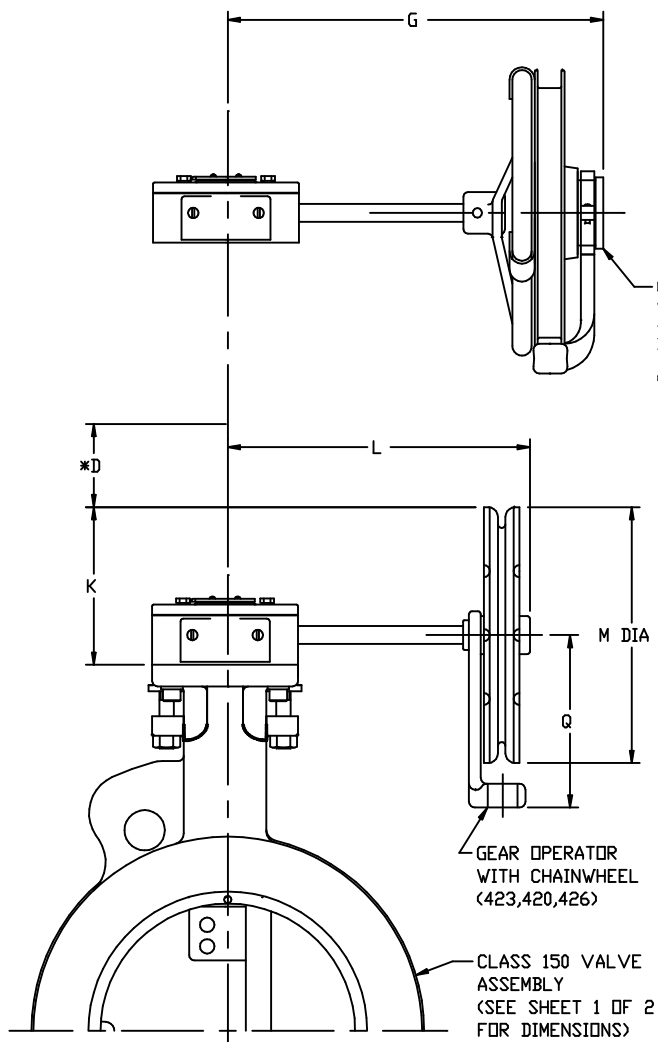

GEAR OPERATOR WITH CHAINWHEEL BABBIT ATTACHED TO HANDWHEEL (430)

GEAR OPERATOR WITH CHAINWHEEL (423,420,426)

CLASS 150 VALVE ASSEMBLY (SEE SHEET 1 OF 2 FOR DIMENSIONS)

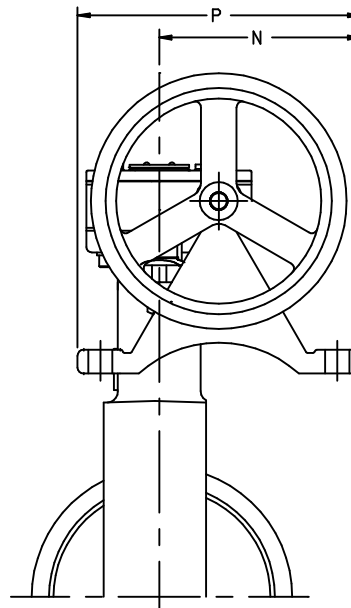

GEAR OPERATOR DIMENSIONS WITH CHAINWHEEL

(METRIC; MM)								
SIZE	G	K	L	M	N	P	Q	ADAPT. CODE
423 (24:1)	N/A	117	179	178	140	191	114	BAC BAD
420 (30:1)	N/A	171	319	275	155	178	184	CAE CAF
426 (50:1)	N/A	234	319	379	167	178	184	CAF
430 (80:1)	341	215	N/A	318	209	178	159	DBC DAJ DAG DAK DAL DAH
(IMPERIAL; INCHES)								
SIZE	G	K	L	M	N	P	Q	ADAPT. CODE
423 (24:1)	N/A	4.6	7.06	7	5.52	7.5	4.5	BAC BAD
420 (30:1)	N/A	6.74	12.56	10.81	6.1	7	7.25	CAE CAF
426 (50:1)	N/A	9.22	12.56	14.94	6.57	7	7.25	CAF
430 (80:1)	13.44	8.45	N/A	12.5	8.22	7	6.25	DBC DAJ DAG DAK DAL DAH

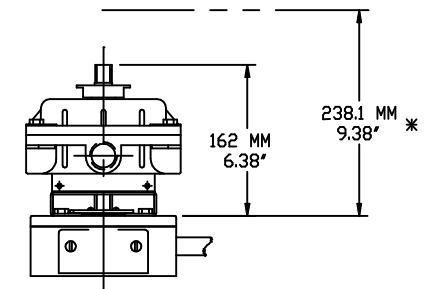

TYPE "A" SWITCHBOX MOUNTED ON GEAR OPERATOR

OPTIONAL



HIGH PERFORMANCE ANSI CLASS 150 BUTTERFLY VALVE W/ GEAR OPERATOR AND OPTIONAL SWITCHBOX (WAFER)

SM1025

2	5899	ERW	2/23/00	KLS	2/00
NO	ECN	DRAWN	DATE	CHECK	DATE