

STANDARD MOUNTING

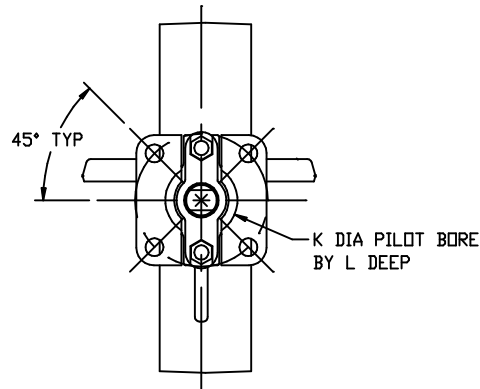

ISO MOUNTING

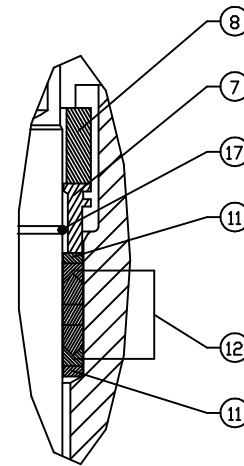

DETAIL A
BRAIDED PACKING

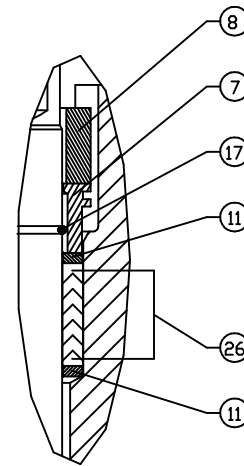

DETAIL A
VEE-CUP

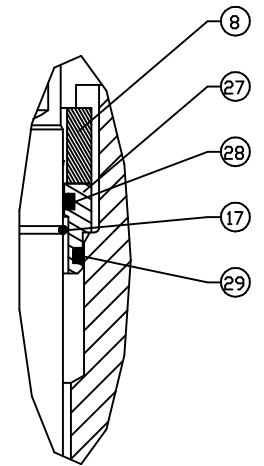

DETAIL A
O-RING

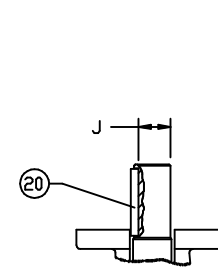
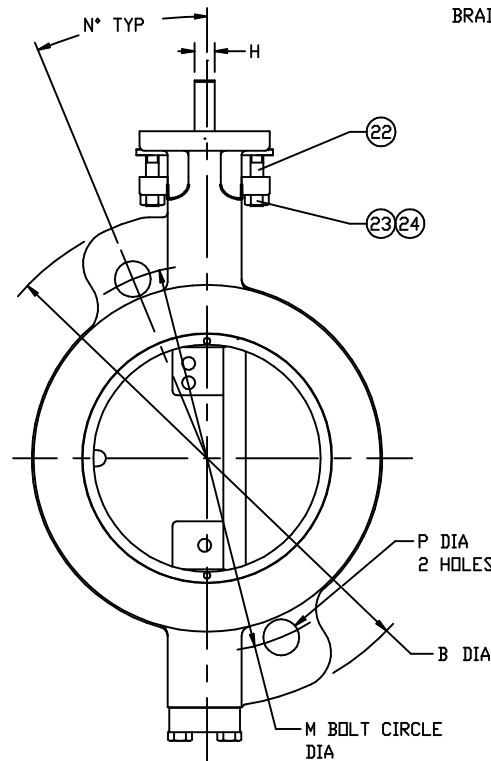
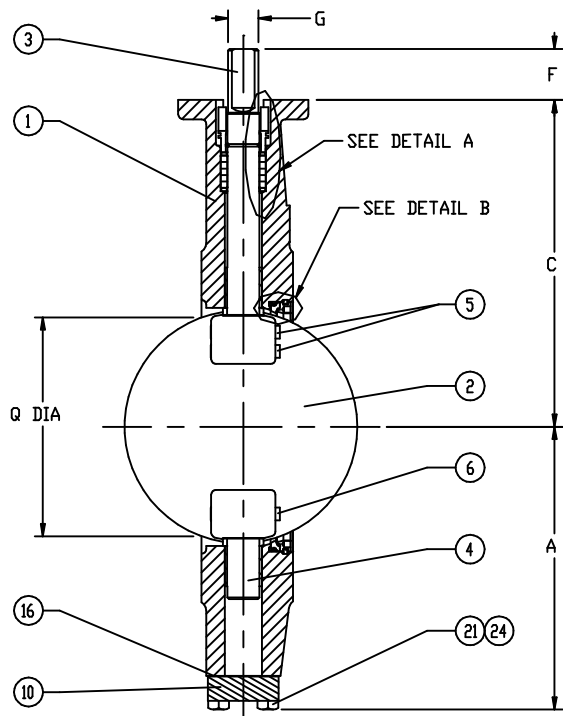

DETAIL B

250mm (10") AND
300mm (12") SIZES
STANDARD MOUNTING ONLY

GRINNELL FLOW CONTROL						HIGH PERFORMANCE VALVE ASSEMBLY DIRECT MOUNT INVERTED PACKING 50MM (2") - 300MM (12") (WAFER)	
						SM1020	
3	05899	ERW	2/23/01	KLS	2/01		
NO	ECN	DRAWN	DATE	CHECK	DATE		

VALVE DIMENSIONS (METRIC; MM)																										
SIZE	A	B	C	Q	E	D	D	KEYSTONE MOUNTING AND TOP PLATE DRILLING					ADAPT CODE	ISO MOUNTING TOP PLATE DRILLING					K	L	ADAPT CODE	WEIGHT (KGS)				
								F	G	H	J	KEY		BOLT CIRCLE	NO. HOLES	HOLE DIA.	F	G					H	BOLT CIRCLE	NO. HOLES	HOLE DIA.
50	96	162	125.5	50	81	43	43	22	11.96	9.49	N _A	N _A	82.6	4	11.1	BBG	25	12	8	50	4	6.6	35	4	F-05	
65	106	182	137	67	81	48	46	31	15.84	11.07	N _A	N _A	82.6	4	11.1	BAC	30	16	11	70	4	9	55	4	F-07	
80	118	200	145.5	74	81	48	46	31	15.84	11.07	N _A	N _A	82.6	4	11.1	BAC	30	16	11	70	4	9	55	4	F-07	
100	133	234	170.5	98	81	54	52	31	15.84	11.07	N _A	N _A	82.6	4	11.1	BAC	30	16	11	70	4	9	55	4	F-07	
125	161	276	185	127	81	57	56	31	19.02	12.67	N _A	N _A	82.6	4	11.1	BAD	30	20	14	70	4	9	55	4	F-07	
150	178	310	203.5	146	81	57	56	31	19.02	12.67	N _A	N _A	82.6	4	11.1	BAD	30	20	14	70	4	9	55	4	F-07	
200	204	362	239	194	118	63.5	60	31	22.19	15.84	N _A	N _A	127	4	14.3	CAF	50	25	18	125	4	13.5	85	4	F-12	
250	240	426	275	243	118	71.5	68	51.8	28.54	N _A	24.85	6.35	127	4	14.3	CAF	50	30	22	125	4	13.5	85	4	F-12	
300	269	490	307	290	118	81	78	51.8	28.54	N _A	24.85	6.35	127	4	14.3	CAF	50	30	22	125	4	13.5	85	4	F-12	

VALVE DIMENSIONS (IMPERIAL; INCHES)																										
SIZE	A	B	C	Q	E	D	D	KEYSTONE MOUNTING AND TOP PLATE DRILLING					ADAPT CODE	ISO MOUNTING TOP PLATE DRILLING					K	L	ADAPT CODE	WEIGHT (LBS)				
								F	G	H	J	KEY		BOLT CIRCLE	NO. HOLES	HOLE DIA.	F	G					H	BOLT CIRCLE	NO. HOLES	HOLE DIA.
2	3.78	6.38	4.94	1.97	3.19	1.69	1.69	.87	.47	3/8	N _A	N _A	3 1/4	4	7/16	BBG	.98	.47	.32	1.97	4	.26	1.38	.16	F-05	
2 1/2	4.17	7.17	5.39	2.64	3.19	1.89	1.81	1.22	.62	7/16	N _A	N _A	3 1/4	4	7/16	BAC	1.18	.63	.43	2.76	4	.35	2.17	.16	F-07	
3	4.65	7.87	5.73	2.91	3.19	1.89	1.81	1.22	.62	7/16	N _A	N _A	3 1/4	4	7/16	BAC	1.18	.63	.43	2.76	4	.35	2.17	.16	F-07	
4	5.24	9.21	6.71	3.86	3.19	2.13	2.05	1.22	.62	7/16	N _A	N _A	3 1/4	4	7/16	BAC	1.18	.63	.43	2.76	4	.35	2.17	.16	F-07	
5	6.34	10.87	7.28	5.00	3.19	2.25	2.20	1.22	.75	1/2	N _A	N _A	3 1/4	4	7/16	BAD	1.18	.79	.55	2.76	4	.35	2.17	.16	F-07	
6	7.01	12.20	8.01	5.75	3.19	2.25	2.20	1.22	.75	1/2	N _A	N _A	3 1/4	4	7/16	BAD	1.18	.79	.55	2.76	4	.35	2.17	.16	F-07	
8	8.03	14.25	9.41	7.64	4.65	2.50	2.36	1.22	.87	5/8	N _A	N _A	5	4	9/16	CAF	1.97	.99	.71	4.92	4	.53	3.35	.16	F-12	
10	9.45	16.77	10.83	9.21	4.65	2.81	2.68	2	1.12	N _A	.98	1/4 x 1/4	5	4	9/16	CAF	1.97	1.18	.87	4.92	4	.53	3.35	.16	F-12	
12	10.59	19.29	12.07	11.42	4.65	3.19	3.11	2	1.12	N _A	.98	1/4 x 1/4	5	4	9/16	CAF	1.97	1.18	.87	4.92	4	.53	3.35	.16	F-12	

PARTS LIST				
ITEM NO.	NAME	NO. REQ'D.	PART NO. & FIG. NO.	REMARKS
1	BODY	1	203-312	
2	DISC	1	204-310	
3	STEM, UPPER	1	205-310	
4	STEM, LOWER	1	205-310	
5	PIN, WEDGE	2	907-310	QTY 1 FOR 50MM (2") THRU 80MM (3")
6	PIN	1	908-733	
7	GLAND	1	216-310	BRAIDED & VEE-CUP ONLY
8	GLAND BRIDGE	1	236-310	
9	BEARING	2	930-310	
10	COVER, BOTTOM	1	259-310	
11	RING, ANTI-EXTRUSION	2	249-310	BRAIDED & VEE-CUP ONLY
12	PACKING	1	928-310	BRAIDED ONLY
13	SEAT	1	206-310	
14	RING, SEAT RETAINER	1	214-310	
15	RETAINER KEY	1	979-310	
16	GASKET	1	921-310	
17	RING, ANTI-BLOWOUT	1	979-310	
18	BEARING, THRUST	2	253-310	
19	O-RING	1	927-730	
20	KEY	1	913-735	250mm (10") AND 300mm (12") SIZE ONLY
21	SCREW	4	905-735	
22	STUD	2	902-735	
23	NUT	4	903-735	
24	WASHER	6	904-735	
25	ID TAG	1	914-310	
26	PACKING, VEE-CUP	1	928-310	VEE-CUP ONLY
27	GLAND	1	216-310	O-RING ONLY
28	O-RING	1	927-730	O-RING ONLY
29	O-RING	1	927-730	O-RING ONLY

NOT SHOWN

NOTES:

- THE VALVE BETWEEN FLANGES IS RATED AT DIN PN 25 OR ANSI 150.
- "Q" DIMENSION IS DEFINED AS THE MINIMUM PIPE OR FLANGE I.D. WHICH WILL SATISFY THE MINIMUM NOMINAL RADIAL DISC TO PIPE CLEARANCE IN MSS SP-68 WITH THE VALVE CENTERED AND WITH 1.5MM / 1/16" GASKET.
- SEE DATA PAGE SM0001 FOR ADAPTABILITY CODE LETTER SYMBOL DIMENSIONS REGULATING INTERCHANGEABILITY OF BODY TOP PLATE MOUNTING TO HANDLES, PLATES, GEAR OPERATORS, POWER ACTUATORS, ETC.
- DIMENSION "D MSS" REFERS TO MSS SP-68 CLASS 150 FACE-TO-FACE DIMENSION. DIMENSION "D ISO" REFERS TO ISO 5752 SHORT (BASIC SERIES 20) FACE-TO-FACE DIMENSION.

GRINNELL FLOW CONTROL					HIGH PERFORMANCE VALVE ASSEMBLY DIRECT MOUNT INVERTED PACKING 50MM (2") - 300MM (12") (WAFER)		
SM1020							
3	05899	ERW	2/23/01	KLS	2/01		
NO	ECN	DRAWN	DATE	CHECK	DATE		
						2 of 2	