

10" (250mm) AND
12" (300mm) SIZES ONLY

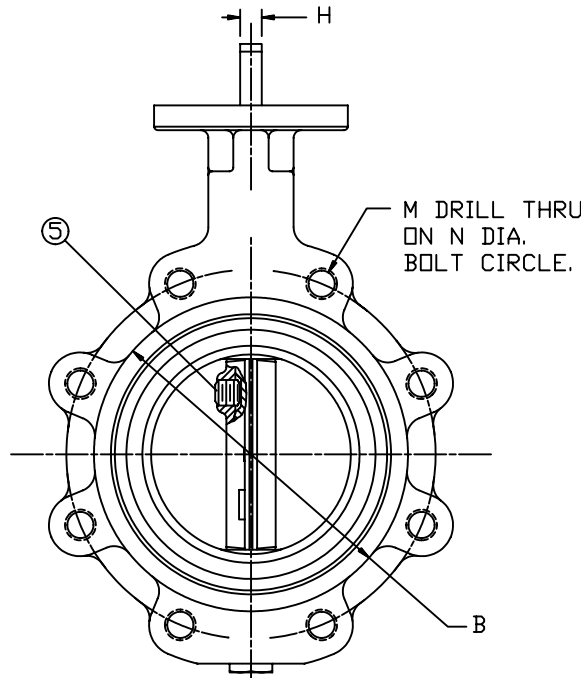
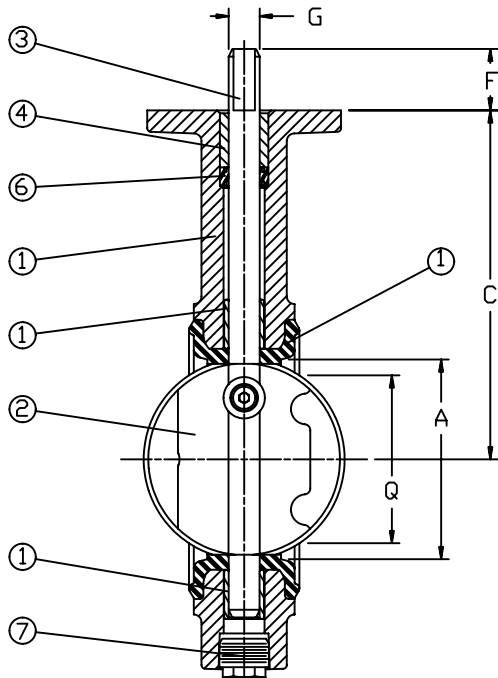

VALVE DIMENSIONS (IMPERIAL: INCHES)

SIZE	A	B	C	D	Q	E	F	G	H	KEY	TOP PLATE DRILLING			WEIGHT LBS	ADAPT. CODE	FLANGE BOLTING-ANSI B16.5 CLASS 150			
											BOLT CIRCLE	NO. HOLES	HOLE DIA.			TAP SIZE "M"	BOLT CIRCLE "N"	NO. BOLTS "P"	
2	2.06	4.13	5.31	1.69	1.38	4	1.25	.56	.38	N/A	3.25	4	.44	9.05	BAB	5/8-11 UNC-2B	4.75	IN	4
2-1/2	2.56	4.63	5.91	1.81	2	4	1.25	.56	.38	N/A	3.25	4	.44	10.55	BAB	5/8-11 UNC-2B	5.50	IN	4
3	3.06	5.19	6.3	1.81	2.63	4	1.25	.56	.38	N/A	3.25	4	.44	11.89	BAB	5/8-11 UNC-2B	6.00	IN	4
4	4.06	6.38	7.09	2.06	3.69	4	1.25	.63	.44	N/A	3.25	4	.44	21.38	BAC	5/8-11 UNC-2B	7.50	IN	8
5	5.06	7.38	7.68	2.25	4.75	4	1.25	.75	.50	N/A	3.25	4	.44	25.71	BAD	3/4-10 UNC-2B	8.50	IN	8
6	5.81	8.50	8.27	2.25	5.56	4	1.25	.75	.50	N/A	3.25	4	.44	30.96	BAD	3/4-10 UNC-2B	9.50	IN	8
8	7.81	10.69	9.45	2.38	7.75	6	1.25	.88	.63	N/A	5	4	.56	48.02	CAE	3/4-10 UNC-2B	11.75	IN	8
10	9.81	13	10.83	2.69	9.75	6	2	1.12	N/A	.25X.25	5	4	.56	75.79	CAF	7/8-9 UNC-2B	14.25	IN	12
12	11.81	14.81	12.2	3.13	11.75	6	2	1.12	N/A	.25X.25	5	4	.56	106.54	CAF	7/8-9 UNC-2B	17.00	IN	12

VALVE DIMENSIONS (METRIC: MM)

SIZE	A	B	C	D	Q	E	F	G	H	KEY	TOP PLATE DRILLING			WEIGHT KG	ADAPT. CODE
											BOLT CIRCLE	NO. HOLES	HOLE DIA.		
50	52	105	135	43	34	102	32	14.27	9.53	N/A	82.5	4	11.1	4.10	BAB
65	64	118	150	46	50	102	32	14.27	9.53	N/A	82.5	4	11.1	4.78	BAB
80	77	132	160	46	67	102	32	14.27	9.53	N/A	82.5	4	11.1	5.39	BAB
100	103	162	180	52	93	102	32	15.88	11.10	N/A	82.5	4	11.1	9.70	BAC
125	128	188	195	56	120	102	32	19.05	12.70	N/A	82.5	4	11.1	11.66	BAD
150	147	218	210	56	141	102	32	19.05	12.70	N/A	82.5	4	11.1	14.04	BAD
200	198	271	240	60	196	152	32	22.23	15.88	N/A	127	4	14.3	21.78	CAE
250	249	330	275	68	247	152	51	28.58	N/A	6.35	127	4	14.3	34.39	CAF
300	300	376	310	78	297	152	51	28.58	N/A	6.35	127	4	14.3	48.33	CAF

PARTS LIST

ITEM NO.	NAME	NO. REQ'D	PART NO. & FIG. NO.	REMARKS
1	BODY	1	203-222	
	SEAT			
	BEARING			
2	DISC	1	204-001	
3	STEM	1	205.222	
4	BUSHING	1	207-100	
5	PLUG	1	922-001	
6	PACKING	1	928-100	
7	PLUG	1	940-736	
8	KEY	1	913-735	10" (250mm) AND 12" (300mm) SIZE ONLY

NOTES:

- THE VALVE BETWEEN FLANGES IS RATED AT 250 PSI (16 BAR) PRESSURE DIFFERENTIAL IN THE CLOSED POSITION.
- BODY IS LUGGED TYPE.
- SEAT AND BEARINGS ARE INTEGRAL WITH BODY.
- "Q" DIMENSION IS THE MINIMUM ALLOWABLE PIPE OR FLANGE INSIDE DIAMETER AT THE CENTERED BODY FACE TO PROTECT THE DISK SEALING EDGE AGAINST DAMAGE WHEN OPENING THE VALVE.
- FULL RATED BI-DIRECTIONAL DEAD-END SERVICE 250 PSI (16 BAR).



VALVE ASSEMBLY
GRINNELL SERIES 1000
LUGGED STYLE

SM1163

2	5379	ERW	10/21/98	JS	10/98
NO	ECN	DRAWN	DATE	CHECK	DATE