

VALVE DIMENSIONS (IMPERIAL: INCHES)

SIZE	A	B	C *	C (SS)	C (AB)	D	E	F	G	H	J	L	M	N	P	S	Q	KEY	ADAPTABILITY CODE
2	3.04	5.09	5.75	4.69	3.93	1.63	4.00	1.25	0.56	0.38	0.406	3.00	3.25	.625-11	4.75	4	1.41	-	BAB
2½	3.25	5.81	6.25	-	4.50	1.75	4.00	1.25	0.56	0.38	0.406	3.00	3.25	.625-11	5.50	4	1.82	-	BAB
3	3.54	6.25	6.50	4.87	4.87	1.75	4.00	1.25	0.56	0.38	0.406	3.00	3.25	.625-11	6.00	4	2.62	-	BAB
4	4.63	7.81	7.25	6.00	6.00	2.00	4.00	1.25	0.63	0.43	0.406	3.00	3.25	.625-11	7.50	8	3.62	-	BAC
5	5.69	8.75	7.75	-	6.00	2.12	4.00	1.25	0.75	0.50	0.406	3.00	3.25	.750-10	8.50	8	4.67	-	BAD
6	6.37	9.75	8.38	6.50	6.50	2.14	4.00	1.25	0.75	0.50	0.406	3.00	3.25	.750-10	9.50	8	5.68	-	BAD
8	7.94	12.00	9.62	8.31	8.31	2.35	6.00	1.25	0.88	0.63	0.562	5.00	-	.750-10	11.75	8	7.54	-	CAE
10	9.38	14.50	11.00	9.50	9.00	2.63	6.00	2.00	1.12	-	0.562	5.00	-	.875-9	14.25	12	9.65	1/4 X 1/4	CAF
12	10.69	17.50	12.50	10.78	10.28	3.00	6.00	2.00	1.37	-	0.562	5.00	-	.875-9	17.00	12	11.49	5/16 X 5/16	CAG

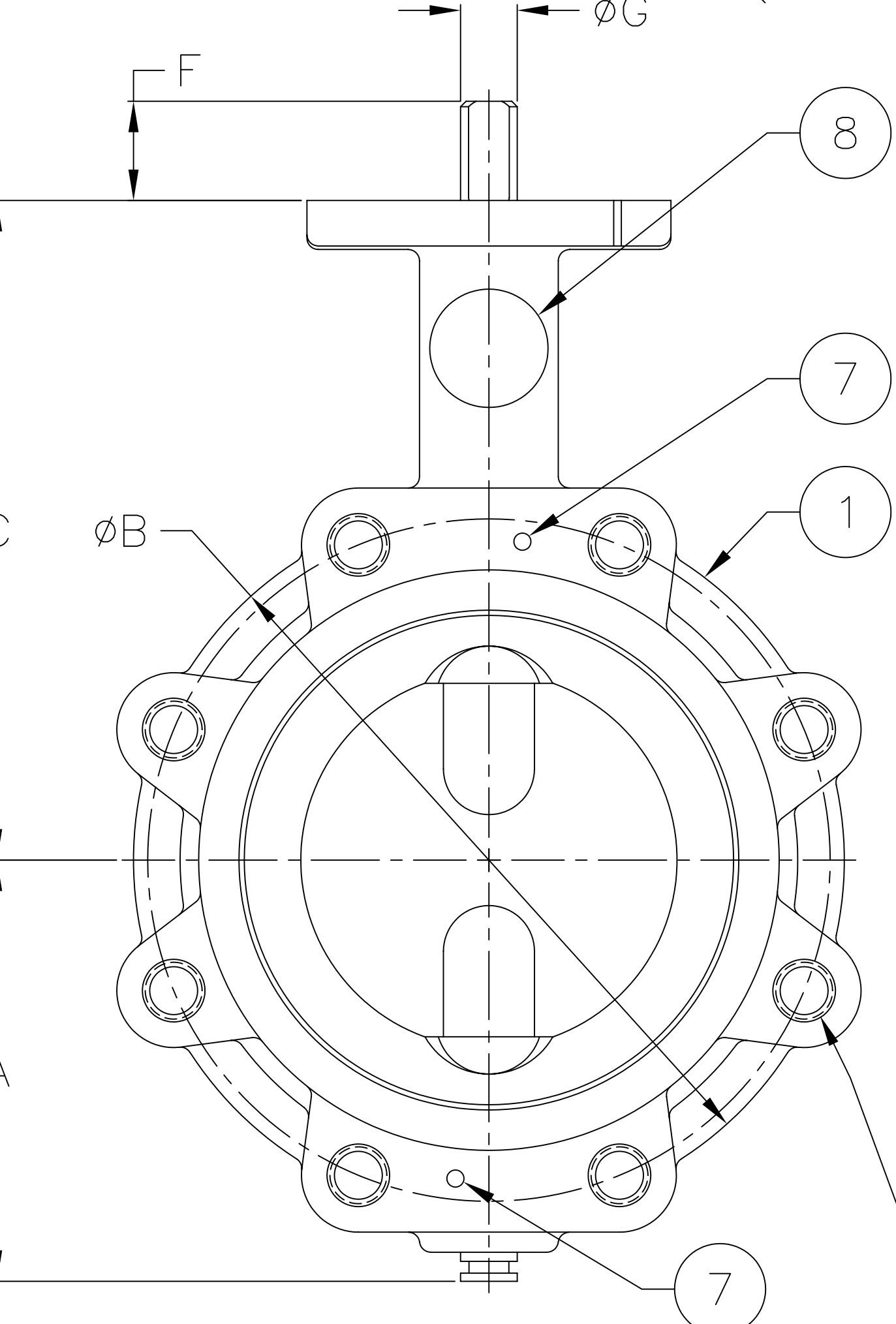

S X N THREAD ON ØP BOLT CIRCLE

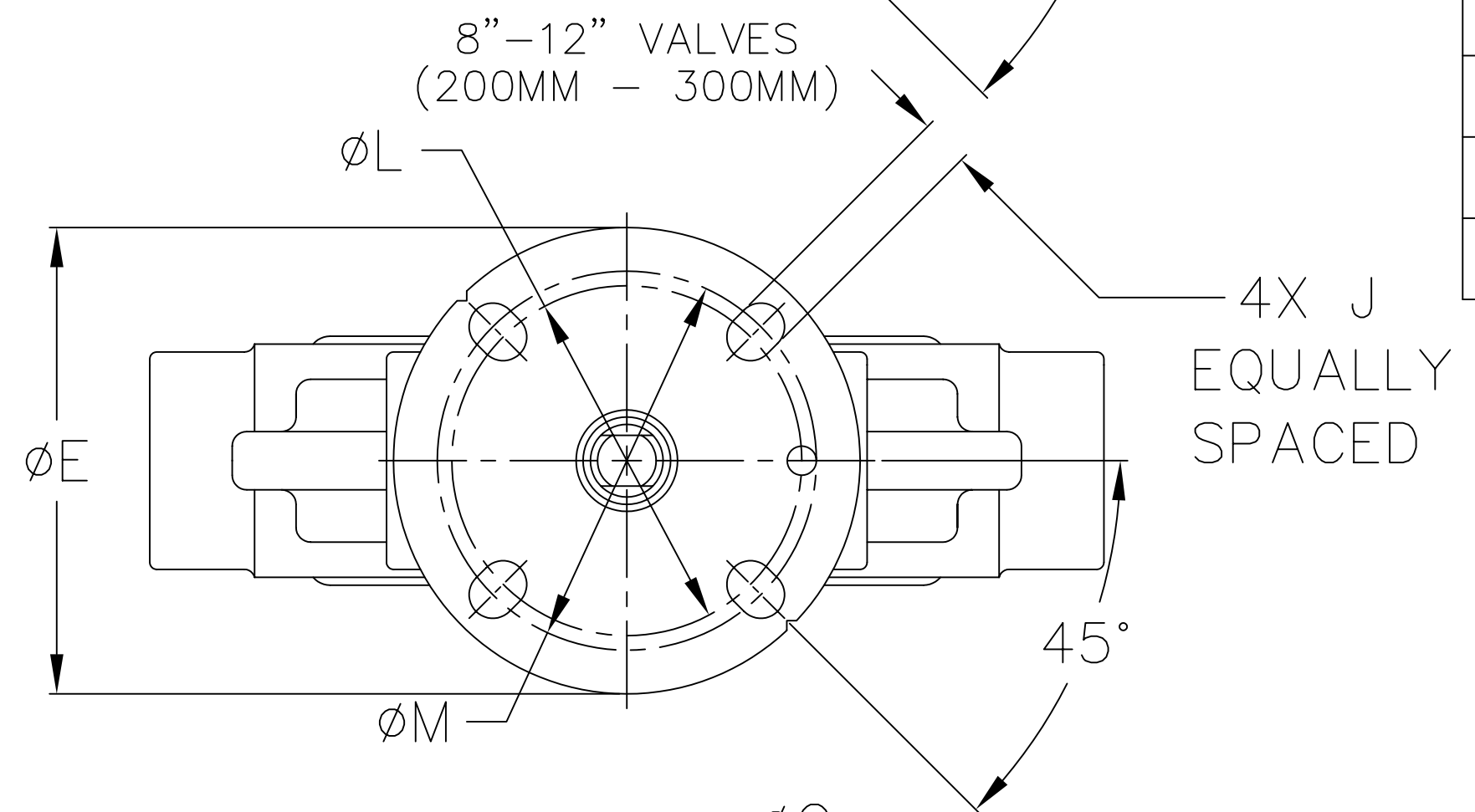
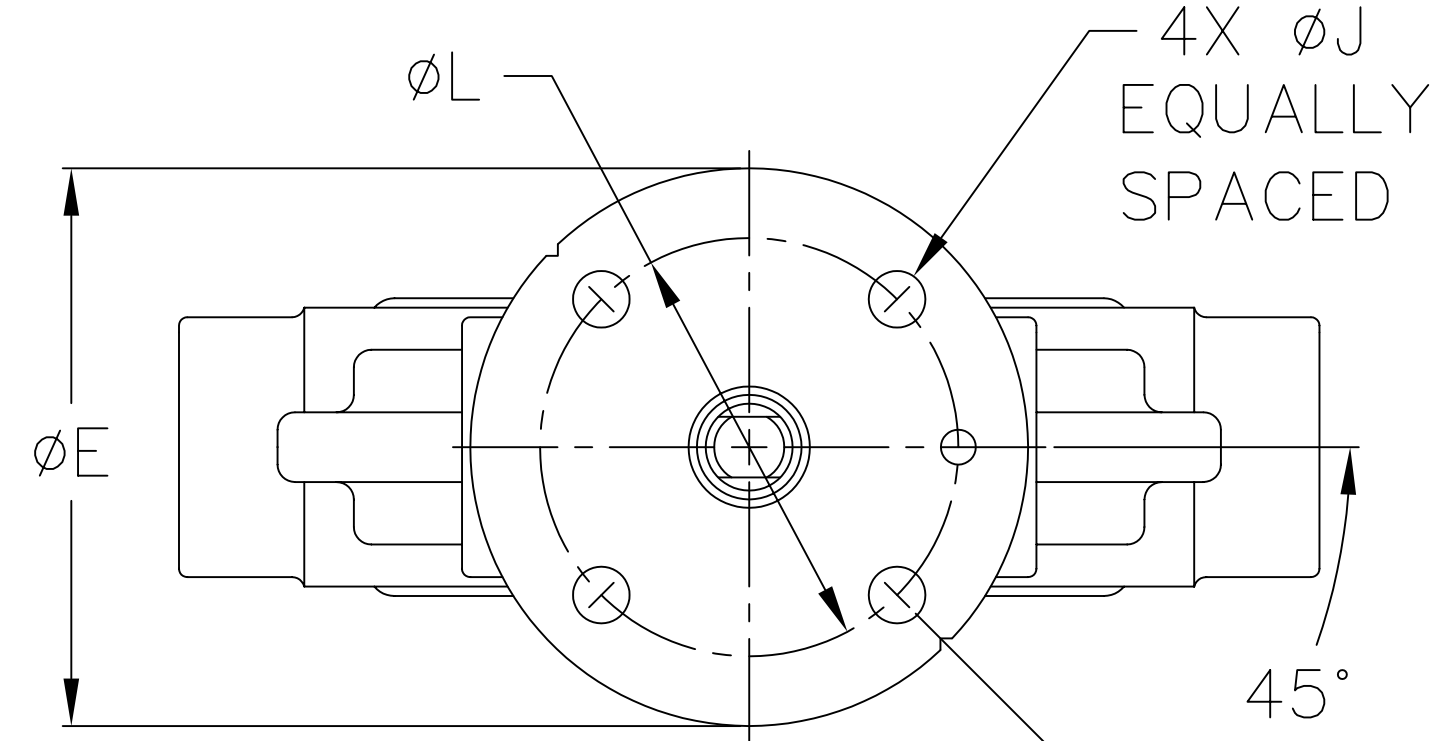
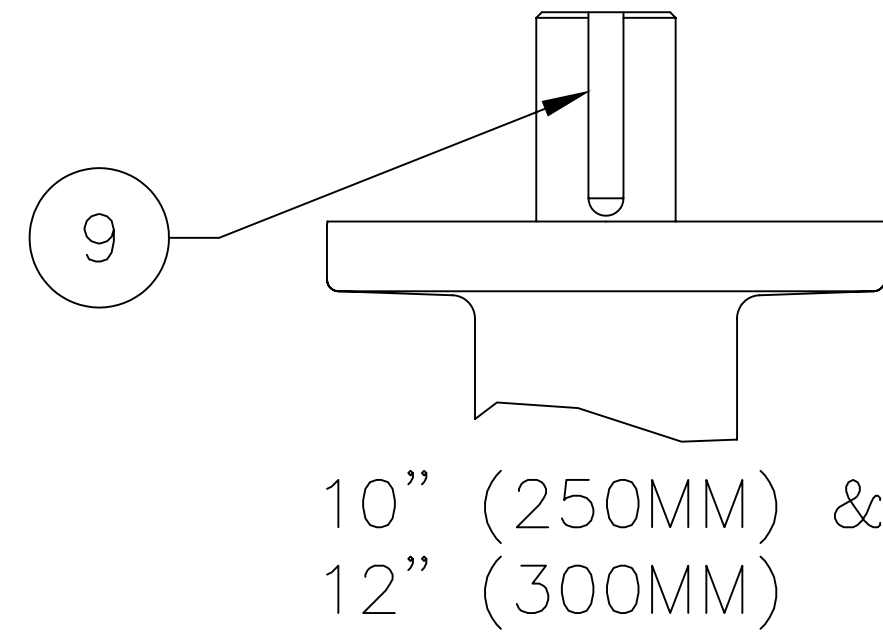
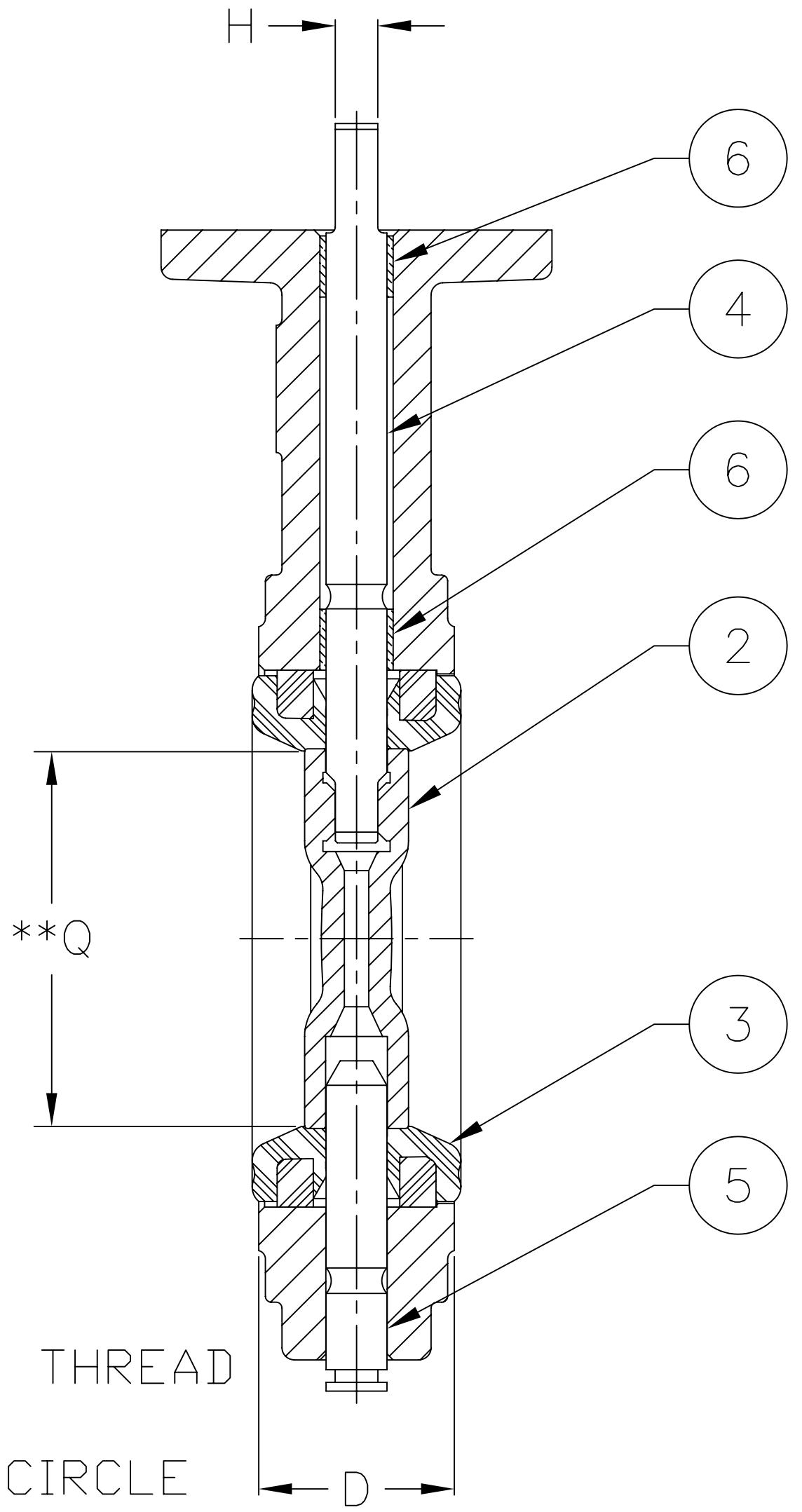

NOTES:

- *1. DIMENSIONS APPLY TO CAST IRON AND DUCTILE IRON BODIES ONLY.
- ** 2. "Q" DIMENSION IS THE MINIMUM ALLOWABLE PIPE OR FLANGE INSIDE DIAMETER AT THE CENTERED BODY FACE TO PROTECT THE DISC SEALING EDGE AGAINST DAMAGE WHEN OPENING THE VALVE.

PARTS LIST			
ITEM NO.	NAME	NO. REQ'D.	REMARKS
1	BODY	1	
2	DISC	1	
3	LINER ASSEMBLY	1	
4	STEM, UPPER	1	
5	STEM, LOWER	1	
6	BEARING	1	
7	PIN, RETENTION	2	
8	TAG	1	
9	KEY	1	10" (250MM) AND 12" (300MM) ONLY

GRINNELL FIGURE 802
VALVE ASSEMBLY
2" (50MM) THRU 12" (300MM)

NO	7359	RDB	03/12/07	JB	03/26/07	SCALE	NTS	SHEET	1 OF 2
----	------	-----	----------	----	----------	-------	-----	-------	--------

SM1251

VALVE DIMENSIONS (METRIC: MM)

SIZE	A	B	C *	C (SS)	C (AB)	D	E	F	G	H	J	L	M	N	P	S	Q	KEY	ADAPTABILITY CODE
50	77.2	129.3	146	119.1	99.8	41.4	101.6	31.8	14.2	9.4	10.3	76.2	82.6	.625-11	120.6	4	35.8	-	BAB
65	82.6	147.6	158.8	-	114.3	44.5	101.6	31.8	14.2	9.4	10.3	76.2	82.6	.625-11	139.7	4	46.2	-	BAB
80	89.9	158.8	165.1	123.7	123.7	44.5	101.6	31.8	14.2	9.4	10.3	76.2	82.6	.625-11	152.4	4	66.5	-	BAB
100	117.6	198.4	184.2	152.4	152.4	50.8	101.6	31.8	15.8	10.9	10.3	76.2	82.6	.625-11	190.5	8	91.9	-	BAC
125	144.5	222.3	196.9	-	152.4	53.8	101.6	31.8	19.1	12.7	10.3	76.2	82.6	.750-10	215.9	8	118.6	-	BAD
150	161.8	247.7	212.9	165.1	165.1	54.4	101.6	31.8	19.1	12.7	10.3	76.2	82.6	.750-10	241.3	8	144.3	-	BAD
200	201.7	304.8	244.3	211.1	211.1	59.7	152.4	31.8	22.1	15.7	14.3	127	-	.750-10	298.5	8	191.5	-	CAE
250	238.3	368.3	279.4	241.3	228.6	66.8	152.4	50.8	28.4	-	14.3	127	-	.875-9	362	12	245.1	6.4 X 6.4	CAF
300	271.5	444.5	317.5	273.8	261.1	76.2	152.4	50.8	34.8	-	14.3	127	-	.875-9	431.8	12	291.8	7.9 X 7.9	CAG

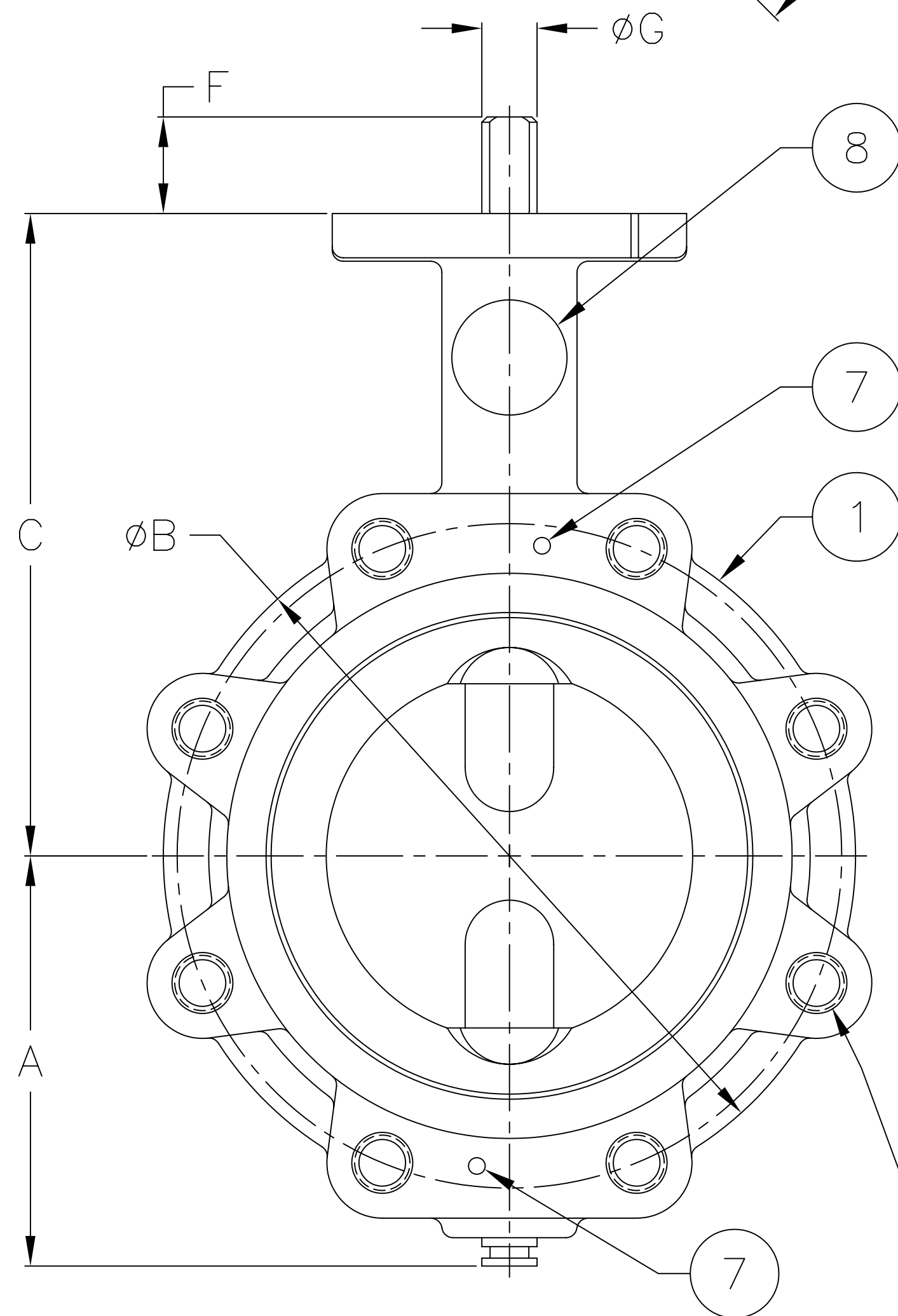
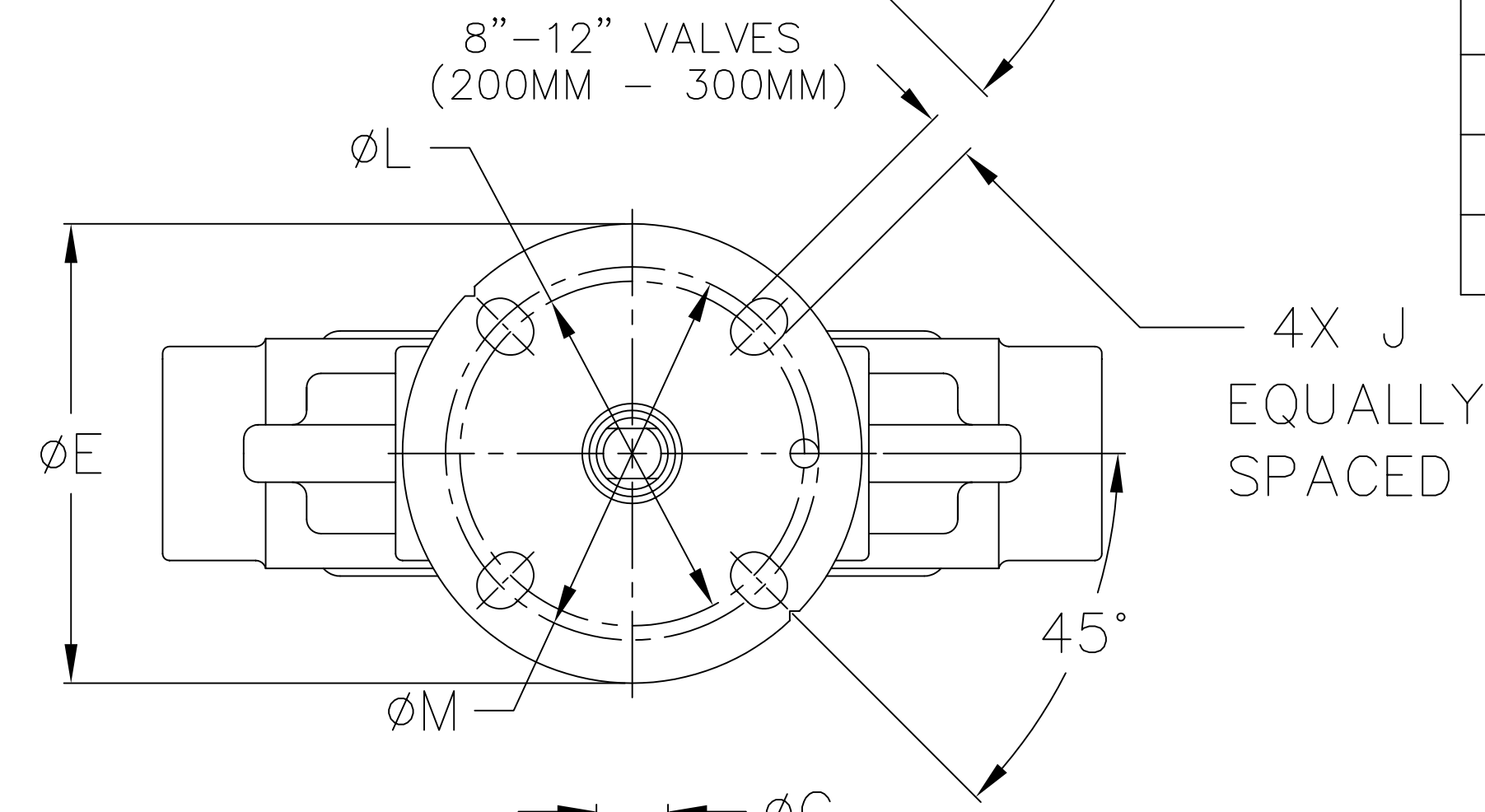
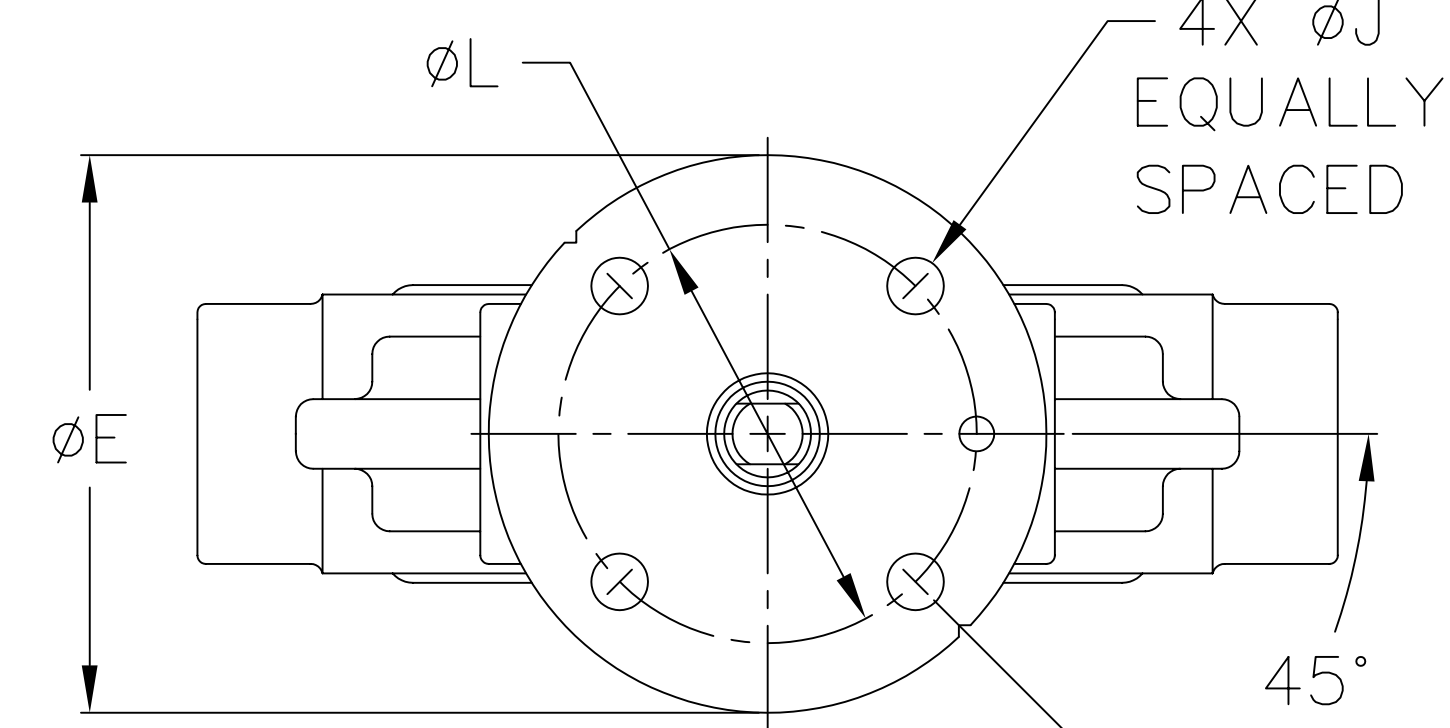

S X N THREAD
ON ØP
BOLT CIRCLE

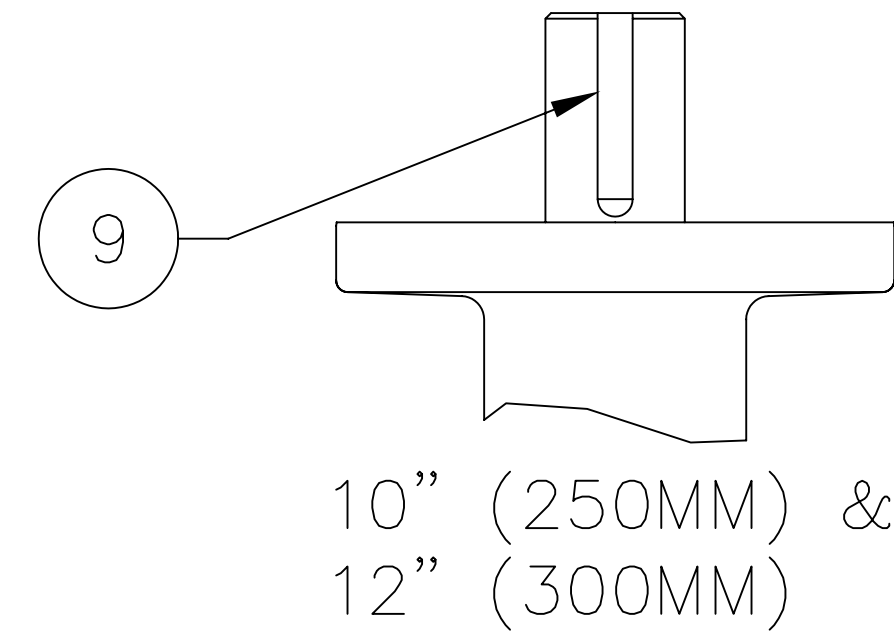
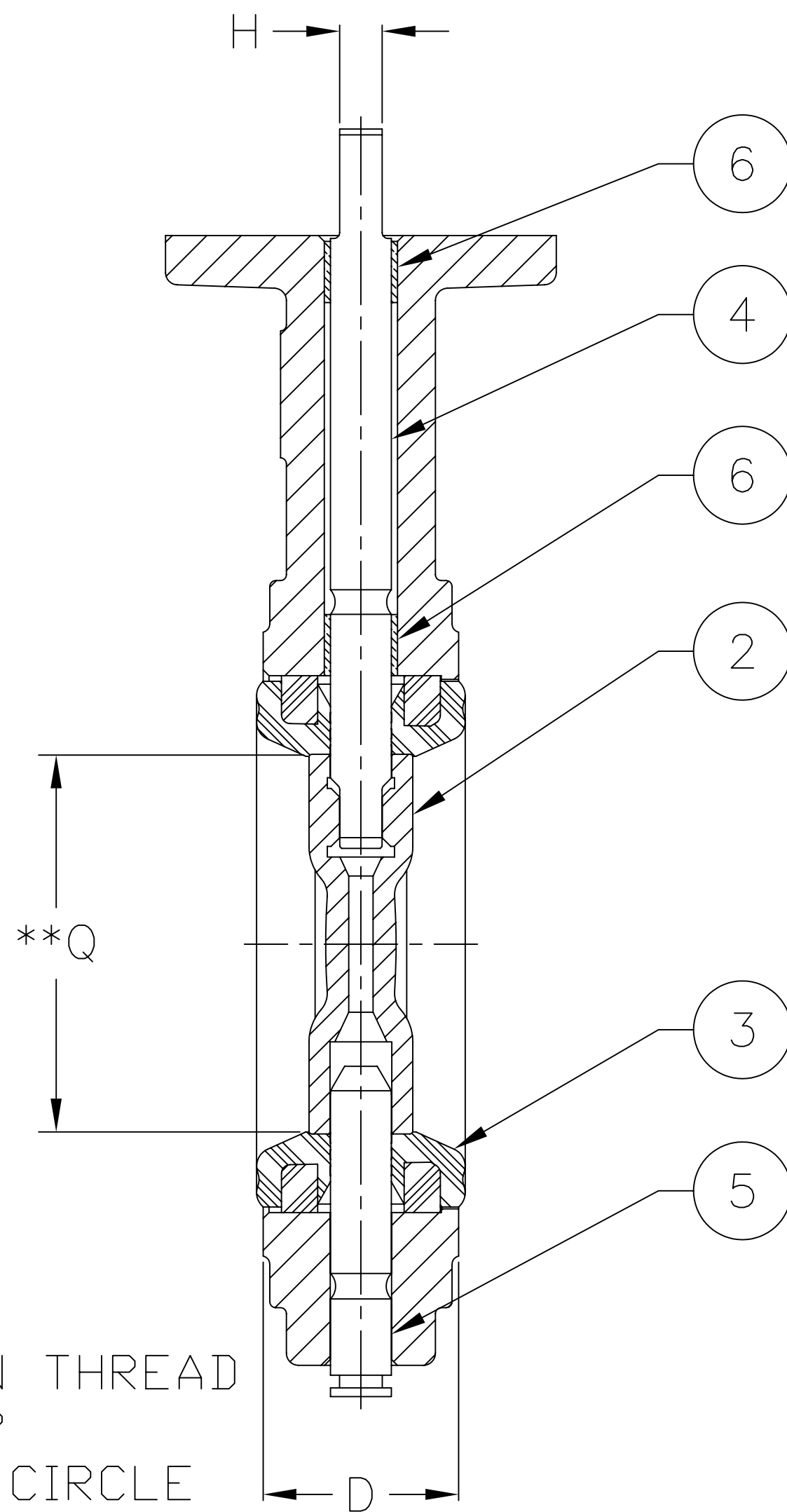

NOTES:

- *1. DIMENSIONS APPLY TO CAST IRON AND DUCTILE IRON BODIES ONLY.
- ** 2. "Q" DIMENSION IS THE MINIMUM ALLOWABLE PIPE OR FLANGE INSIDE DIAMETER AT THE CENTERED BODY FACE TO PROTECT THE DISC SEALING EDGE AGAINST DAMAGE WHEN OPENING THE VALVE.

PARTS LIST			
ITEM NO.	NAME	NO. REQ'D.	REMARKS
1	BODY	1	
2	DISC	1	
3	LINER ASSEMBLY	1	
4	STEM, UPPER	1	
5	STEM, LOWER	1	
6	BEARING	1	
7	PIN, RETENTION	2	
8	TAG	1	
9	KEY	1	10" (250MM) AND 12" (300MM) ONLY

						GRINNELL FIGURE 802 VALVE ASSEMBLY 2" (50MM) THRU 12" (300MM)			
						SIZE	SM1251		
1	7359	RDB	03/12/07	JB	03/26/07	SCALE	NTS	SHEET	2 OF 2
NO	ECN	DRAWN	DATE	CHECK	DATE				